

L-force *Drives*

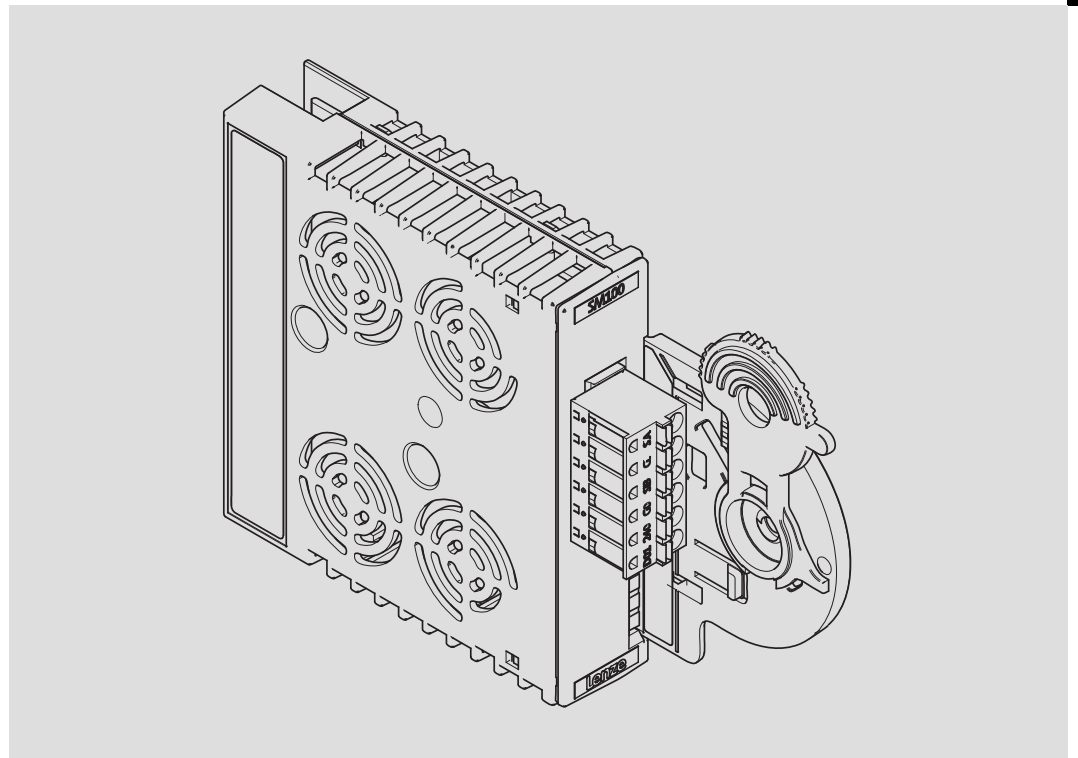

Manual

9400



E94AYAB - SM100

Safety module



Please read these instructions and the documentation of the standard device before you start working!

Observe the safety instructions given therein!

1	Safety engineering	4
1.1	Basics	4
1.1.1	Introduction	4
1.1.2	Drive-based safety with L-force 9400	4
1.1.3	Terms and abbreviations of the safety engineering	5
1.1.4	Important notes	6
1.1.5	Safety instructions	7
1.1.6	Hazard and risk analysis	9
1.1.7	Standards	9
1.1.8	Safety notes for the installation according to UL or UR	9
1.1.9	Overview of sensors	9
1.3	Device modules	11
1.3.1	Slot	11
1.3.2	Function mode of the safety modules	12
1.3.3	Safety module SM0	13
1.3.4	Safety module SM100	14
1.4	Acceptance	19
1.4.1	Description	19
1.4.2	Periodic inspections	19

1 Safety engineering

Basics

Introduction

1 Safety engineering

1.1 Basics

1.1.1 Introduction

With increasing automation, protection of persons against hazardous movements is becoming more important. Functional safety describes the measures needed by means of electrical or electronic equipment to reduce or remove danger caused by failures.

During normal operation, safety equipment prevents people accessing hazardous areas. In certain operating modes, e.g. set-up mode, work needs to be carried out in hazardous areas. In these situations the machine operator must be protected by integrated drive and control measures.

Drive-based safety provides the conditions in the controls and drives to optimise the safety functions. Planning and installation expenditure is reduced. In comparison to the use of standard safety engineering, drive-based safety increases machine functionality and availability.

1.1.2 Drive-based safety with L-force | 9400

The controllers of the L-force|9400 range can be equipped with a safety module. The functional range of the safety module types varies in order to optimally implement different applications.

”Drive-based safety” stands for applied safety functions, which can be used for the protection of persons working on machines.

The motion functions are continued to be executed by the controller. The safety modules monitor the safe compliance with the limit values and provide the safe inputs and outputs. When the limit values are exceeded the safety modules start the control functions according to EN 60204-1 directly in the controller.

The safety functions are suitable for applications according to IEC 61508 to SIL 3 and meet, depending on the module, the requirements of Performance Level e (PL e) and control category 4 according to EN ISO 13849-1.

1.1.3 Terms and abbreviations of the safety engineering

Abbreviation	Meaning
9400	Lenze servo controller
Cat.	Category according to ISO 13849-1 (formerly EN 954-1)
OSSD	Output Signal Switching Device, tested signal output
PS	PROFIsafe
PWM	Pulse width modulation
SD-In	Safe input (Safe Digital Input)
SD-Out	Safe output (Safe Digital Output)
SIL	Safety Integrity Level according to IEC 61508
SM	Safety Module
Opto supply	Optocoupler supply for the driver control
PELV	Protective extra low voltage
SELV	Safety extra low voltage
OFF state	Signal state of the safety sensor technology when it is released or responding
ON state	Signal state of the safety sensor technology in normal operation
PM	P/N switching signal paths
PP	P/P switching signal paths
GSE	File containing device-specific data to establish PROFIBUS communication
GSDML	File containing device-specific data to establish PROFINET communication
S-Bus	Safety bus
Abbreviation	Safety function
SLS	Safely limited speed
SOS	Safe operating stop
SS1	Safe stop 1
SS2	Safe stop 2
SSM	Safe speed monitor
STO	Safe torque off Formerly: safe standstill

1 Safety engineering

Basics

Important notes

1.1.4 Important notes

The following pictographs and signal words are used in this documentation to indicate dangers and important information:

Safety instructions

Structure of safety instructions:





Danger!



(characterises the type and severity of danger)

Note



(describes the danger and gives information about how to prevent dangerous situations)

Pictograph and signal word	Meaning
 Danger!	Danger of personal injury through dangerous electrical voltage. Reference to an imminent danger that may result in death or serious personal injury if the corresponding measures are not taken.
 Danger!	Danger of personal injury through a general source of danger. Reference to an imminent danger that may result in death or serious personal injury if the corresponding measures are not taken.
 Stop!	Danger of property damage. Reference to a possible danger that may result in property damage if the corresponding measures are not taken.

Application notes

Pictograph and signal word	Meaning
 Note!	Important note to ensure troublefree operation
 Tip!	Useful tip for simple handling
	Reference to another documentation

Special safety instructions and application notes for UL and UR

Pictograph and signal word	Meaning
 Warnings!	Safety or application note for the operation of a UL-approved device in UL-approved systems. Possibly the drive system is not operated in compliance with UL if the corresponding measures are not taken.
 Warnings!	Safety or application note for the operation of a UR-approved device in UL-approved systems. Possibly the drive system is not operated in compliance with UL if the corresponding measures are not taken.

1.1.5 Safety instructions

Application as directed

The safety modules SMx (E94AYAx) may only be used together with Lenze drive controllers of the L-force | 9400 (E94A...) series.

Any other use shall be deemed inappropriate!

Installation/commissioning



Danger!

Danger to life through improper installation

Improper installation of the safety engineering systems can cause an uncontrolled starting action of the drives.

Possible consequences:

- ▶ Death or severe injuries

Protective measures:

- ▶ Safety engineering systems may only be installed and commissioned by qualified and skilled personnel.
- ▶ All control components (switches, relays, PLC, ...) and the control cabinet must comply with the requirements of ISO 13849-1 and ISO 138492. This includes i.a.:
 - Switches, relays in IP54 enclosure.
 - Control cabinet in IP54 enclosure.
 - Please refer to ISO 13849-1 and ISO 138492 for all further requirements.
- ▶ It is essential to use insulated wire end ferrules for wiring.
- ▶ All safety relevant cables outside the control cabinet must be protected, e.g. by means of a cable duct:
 - Ensure that there are no short circuits.
 - For further measures see ISO 138492.
- ▶ If an external force acts upon the drive axes, additional brakes are required. Please observe that hanging loads are subject to the force of gravity!

**Danger!**

If the request for the safety function is cancelled, the drive will restart automatically.

You must provide external measures which ensure that the drive only restarts after a confirmation (EN 60204).

**Danger!**

When the "safe torque off" (STO) function is used, an "emergency switching-off" according to EN 60204 is not possible without additional measures. There is no electrical isolation, no service switch or repair switch between motor and controller!

"Emergency switching-off" requires an electrical isolation, e.g. by a central mains contactor!

During operation

After the installation is completed, the operator must check the wiring of the safety function.

The functional test must be repeated at regular intervals. The time intervals to be selected depend on the application, the entire system and the corresponding risk analysis. The inspection interval should not exceed one year.

Residual hazards

In case of a short-circuit of two power transistors a residual movement of the motor of up to $180^\circ/\text{number of pole pairs}$ may occur! (Example: 4-pole motor \Rightarrow residual movement max. $180^\circ/2 = 90^\circ$)

This residual movement must be considered in the risk analysis, e.g. safe torque off for main spindle drives.

1.1.6 Hazard and risk analysis

This documentation can only accentuate the need for a hazard analysis. The user of drive-based safety must concentrate on dealing with the standards and legal position:

Before putting a machine into circulation, the manufacturer of the machine must carry out a hazard analysis according to the Machinery Directive 2006/42/EC (until 28 December 2009: 98/37/EC) to find out the hazards related to the application of the machine. To achieve a level of safety as high as possible the Machinery Directive contains three principles:

- ▶ Removing or minimising the hazards by the construction itself.
- ▶ Taking the protective measures required against hazards that cannot be removed.
- ▶ Documentation of the existing residual risks and training of the user regarding these risks.

The execution of the hazard analysis is specified in EN 1050, guidelines for risk assessment. The result of the hazard analysis determines the category of safety-based control modes according to EN ISO 13849-1 which the safety-oriented parts of the machine control must comply with.

1.1.7 Standards

Safety regulations are confirmed by laws and other governmental guidelines and measures and the prevailing opinion among experts, e.g. by technical regulations.

The regulations and rules to be applied must be observed in accordance with the application.

1.1.8 Safety notes for the installation according to U_L or U_R



Warnings!

- ▶ Maximum surrounding air temperature: 55 °C.
- ▶ External fuse for 24 Vdc supply voltage. Rated 4 A DC fuse UL248-14.

1.1.9 Overview of sensors

Passive sensors

Passive sensors are two-channel switching elements with contacts. The connecting cables and the sensor function must be monitored.

The contacts must switch simultaneously (equivalently). Nevertheless, safety functions will be activated as soon as at least one channel is switched.

The switches must be wired according to the closed-circuit principle.

Examples of passive sensors:

- ▶ Door contact switch
- ▶ Emergency-off control units

Active sensors

Active sensors are units with two-channel semiconductor outputs (OSSD outputs). Drive-based safety integrated in this device series allows for test pulses < 1 ms to monitor the outputs and cables.

P/N-switching sensors switch the positive and negative cable or signal and earth cable of a sensor signal.

The outputs must switch simultaneously. Nevertheless, safety functions will be activated as soon as at least one channel is switched.

Examples of active sensors:

- ▶ Lightgrid
- ▶ Laser scanner
- ▶ Control

1.2 Device modules

1.2.1 Slot

The slot for the safety modules is marked in the documentation with M4. It is the lowest slot in the controller (see overview in the documentation of the controller).

1.2.1.1 Mounting

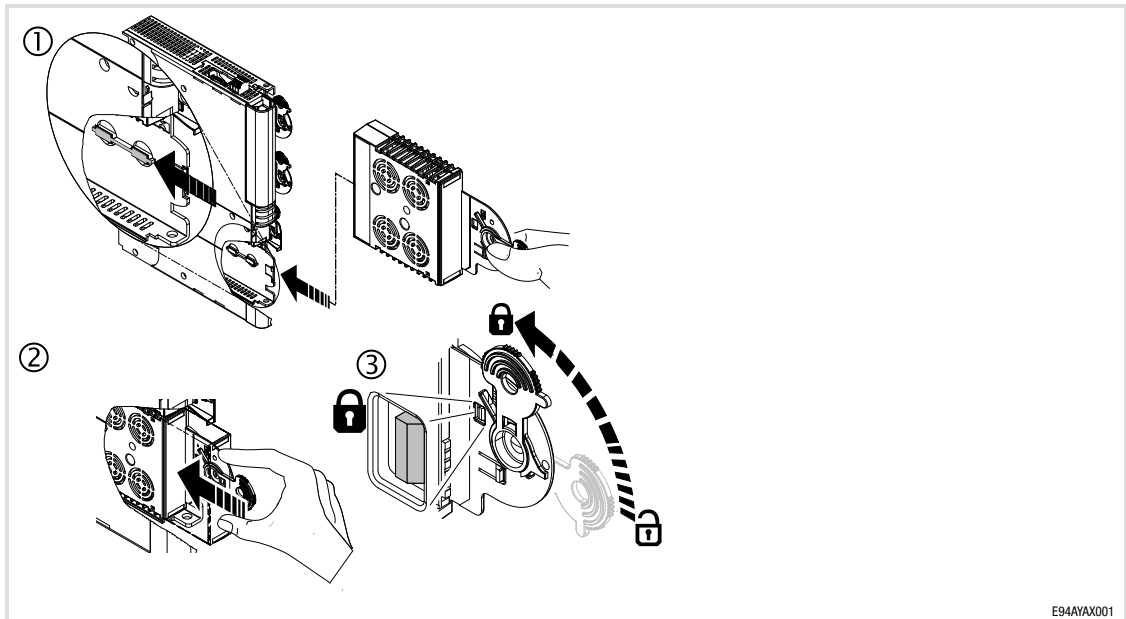

1.2.1.2 Dismounting

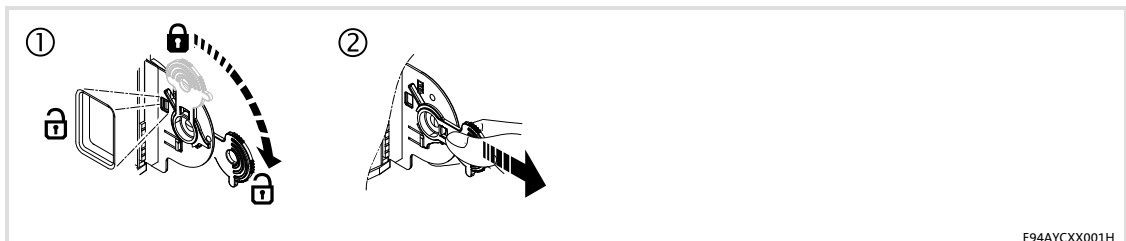

1.2.1.3 Module exchange

Every module exchange is detected by the standard device and documented in a logbook.

When a module is replaced by the same type, no restrictions arise. Depending on the module type it may be necessary to take further measures (e.g. address setting, safe parameter setting, ...).

When the module is replaced by a different type, the drive is inhibited by the controller. The inhibit can only be deactivated when the parameter setting of the required safety module complies with the plugged safety module.

1.2.2 Function mode of the safety modules

C00214

The code C00214 must comply with the plug-in safety module type so that the controller is able to operate.

Disconnecting paths

The transmission of the pulse width modulation is safely (dis-)connected by the safety module. Hence the drivers do not create a rotating field. The motor is safely switched to torqueless operation (STO).

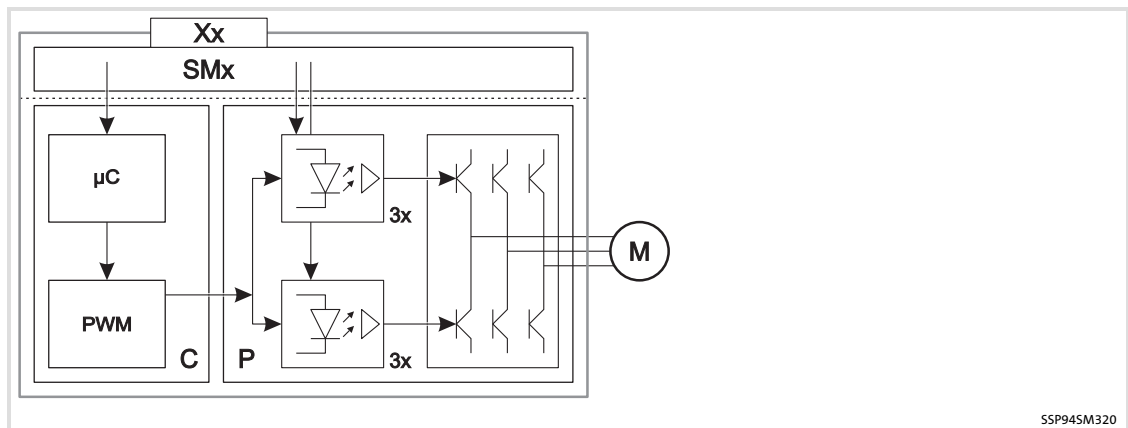

Fig. 1-1 Disconnecting paths of the safety modules

SMx	Safety module
xx	Input / output terminal
C	Control section
μC	Microcontroller
PWM	Pulse width modulation
P	Power section
M	Motor

Safety status

When the controller is switched off by the safety module, the controller switches to the "Safe torque off" device state.

- ▶ "Controller in STO state" is entered into the logbook (0x00750003).
- ▶ "Safe torque off active" is displayed in C00183.

1.2.3 Safety module SM0

1.2.3.1 Overview

The type designation of the module is E94AYAA.

Function

- ▶ There are **no** safety functions available.
- ▶ This module is required to operate the controller without safetyfunctions.



Note!

If safety functions are required, replace the SM0 module by a module with safety functions (e.g. SM100, SM301).



Note!

After the module has been exchanged, the controller does not work if the module type plugged-in does not comply with the stored type (C00214).

1 Safety engineering

Device modules
Safety module SM100

1.2.4 Safety module SM100

1.2.4.1 Overview

The type designation of the safety module is E94AYAB.

Function

- ▶ Safe torque off
(up to now: Safe standstill, protection against unexpected start-up)



Danger!

If the request for the safety function is cancelled, the drive will restart automatically.

You must provide external measures which ensure that the drive only restarts after a confirmation (EN 60204).



Fig. 1-2 Function overview SM100

SM100	Safety module
SIA, SIB, GI	Two-channel sensor signal connections, supply through safely separated power supply unit (SELV/PELV) (old labelling up to HW version VB: SI1, SI2, GI)
240, DO1, GO	Non-safe feedback connections, supply through safely separated power supply unit (SELV/PELV)
µC	Microcontroller
PWM	Pulse width modulation

1.2.4.2 Safety category

The functions of the SM100 safety module for the Servo Drives 9400 controllers meet the requirements of the following standards:

- ▶ Category 4 and Performance Level e (PL e) according to ISO 13849-1 (formerly EN 954-1)
 - In order to comply with category 4/PL e, the external wiring and cable monitoring must also meet the requirements of category 4/PL e.
 - Ensure that short circuits cannot occur in the external wiring.
- ▶ SIL 3 according to IEC 61508
 - The SM100 safety module does not contribute to the probability of failure on demand (PFD) and probability of failure per hour (PFH) of IEC 61508.

1.2.4.3 Elements of the module

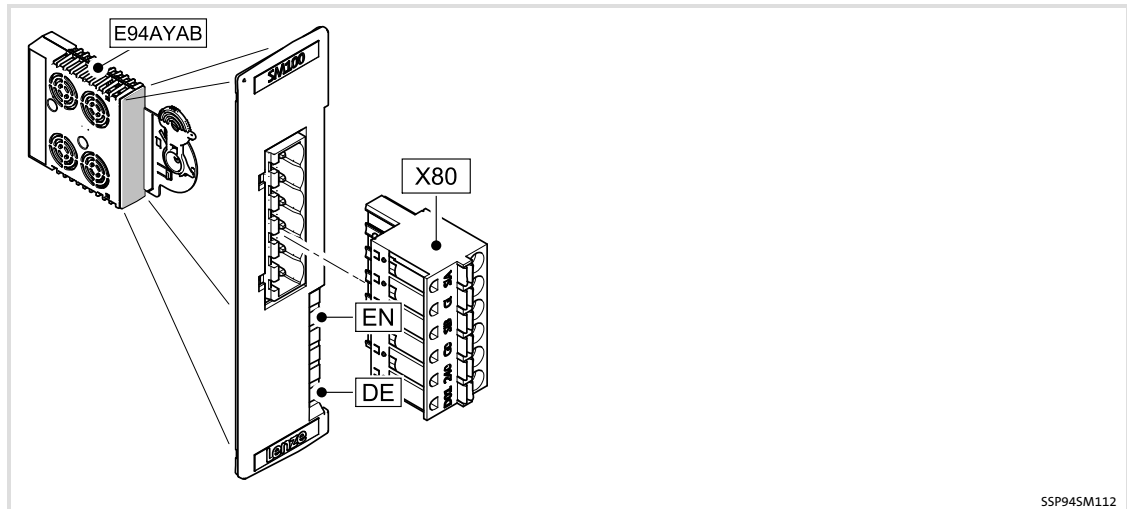

Fig. 1-3 Module view

Displays

Pos.	Colour	Condition	Description
EN	Yellow	On	Controller enabled
		Off	Non-safe display "Safe pulse inhibit"
DE	Red	On	The module is not accepted by the standard device (see notes given in the documentation for the standard device).

Tab. 1-1 LED display SM 100

1.2.4.4 Technical data

24 V

The inputs and outputs are isolated and designed for a low-voltage supply through a safely separated power supply unit (SELV/PELV) of 24 V DC. P/N switching input signals and test pulses ≤ 1 ms are permissible.

Output signals of active sensors are directly wired to the X80 terminal.

Passive Sensors are wired to the X80 terminal via a switching device. The switching device must comply with the required control category of the application.

There is no monitoring for short circuits.

Signals

X80	Marking	Description	Electrical data
	SIA	Input first shutdown path	SIA: $I_{typ} = 160 \text{ mA}$
	GI	GND potential for SIA/SIB	LOW: $-3 \dots 5 \text{ V}$, HIGH: $15 \dots 30 \text{ V}$,
	SIB	Input second shutdown path	SIB: $I_{typ} = 28 \text{ mA}$
	GO	GND potential feedback	Supply through safely separated power supply unit (SELV/PELV)
	24O	24 V supply feedback	24 V, max. 0.7 A, short-circuit-proof, LOW-active,
	DO1	Non-safe signalling output: "Safe pulse inhibit"	Supply through safely separated power supply unit (SELV/PELV)

SSP9400X80

Terminal data				
	Conductor cross-section		Tightening torque	
	[mm ²]	[AWG]	[Nm]	[lb-in]
Rigid	0.2 ... 2.5	24 ... 12	Spring terminal	
Wire end ferrule, insulated	0.2 ... 1.5	24 ... 16		
Twin wire end ferrule	0.5 ... 1.0	20 ... 18		

Stripping length / contact length: 10 mm

Information for the exchange of modules of different hardware versions		
up to HW: VB	from HW: VC	Comment
SI1	SIA	The exchange of the spring terminal is required!
GI	GI	
SI2	SIB	
GO	GO	
24O	24O	
DO1	DO1	

Detail features of the inputs and outputs of the SM100					
Terminal	Specification	[Unit]	min.	typ.	max.
SIA, SIB	Low signal	V	-3	0	5
	High signal	V	15	24	30
	Input capacitance at switch-off	nF		4	
	Input delay (tolerated test pulse)	ms		1	
	Switch-off time (depending on the standard device)	ms	2.5	4	
	Running time	ms		3	
SIA	Input current	mA		160	170
	Input capacitance at switch-on, reduced	μF		20	
SIB	Input current	mA		28	35
	Input capacitance at switch-on, reduced	μF		5	
GI	Ground for SIA/SIB				
240, GO	Supply voltage through safely separated power supply unit (SELV/PELV)	V	18	24	30
DO	Low signal	V		0	0.8
	High signal	V	17	24	29
240, GO, DO	Output current	A			0.7

Truth table

Inputs		Outputs	Description	Enable
SIA	SIB	DO1		through SM100
0	0	1	"Safe torque off" is activated	0
0	1	0		0
1	0	0		0
1	1	0	Drive is active	1

Tab. 1-2 Truth table SM100

1.2.4.5

Commissioning

- ▶ Settings in or at the module are not required.
- ▶ Required settings in the basic device:
 - C00214, type of safety module
- ▶ During commissioning and after the replacement of a module it is vital to check the safety function.

1.2.4.6 Test certificate

 ZERTIFIKAT CERTIFICATE		Nr./No. 968/EL 325.02/07
Prüfgegenstand Product tested	Safety Module	Hersteller Manufacturer Lenze Drive Systems GmbH Hans-Lenze-Straße 1 31855 Aerzen Germany
Typbezeichnung Type designation	SM 100 E94AYAB	Verwendungszweck Intended application Realization of „Safe Torque Off“ (STO) at drive systems
Prüfgrundlagen Codes and standards forming the basis of testing	EN ISO 13849-1:2006 EN 60204-1:2006 EN 50178:1997 EN 61800-3:2004 EN 61508, parts 1-7: 2001 EN 62061:2005 IEC 61800-5-2:2007	
Prüfungsergebnis Test results	The requirements of the applicable standards are fulfilled. The SM 100 as a pluggable safety module for the converter family 9400 fulfils the requirements up to the safety category 4 and PL e according to EN ISO 13849-1 and up to SIL 3 according to EN 61508:EN 62061.	
Besondere Bedingungen Specific requirements	The instructions of the Installation and Operating Manual have to be considered.	
<p>Der Prüfbericht-Nr. 968/EL 325.02/07 vom 01.10.2007 ist Bestandteil dieses Zertifikates. Dieses Zertifikat ist nur gültig für Erzeugnisse, die mit dem Prüfgegenstand übereinstimmen. Es wird ungültig bei jeglicher Änderung der Prüfgrundlagen für den angegebenen Verwendungszweck.</p> <p>The test report-no. 968/EL 325.02/07 dated 2007-10-01 is an integral part of this certificate. This certificate is valid only for products which are identical with the product tested. It becomes invalid at any change of the codes and standards forming the basis of testing for the intended application.</p>		
TÜV Rheinland Industrie Service GmbH Geschäftsbereich ASI <small>Auditorien, Software und Informationsdienste Am Graeven Steinle, 51159 Köln Postfach 91 09 91, 51101 Köln</small>		
2007-10-01 Datum/Date	Firmenstempel/Company seal	Dipl.-Ing. Klaus Kemp

Zertifikat_el325

Fig. 1-4 TÜV Certificate

The type test was carried out by 'TÜV Rheinland Group' and confirmed with a certificate.

Contents	Specifications
Test institute	TÜV Rheinland Industrie Service GmbH, ASI business area
Test report	968/EL 325.02/07
Test fundamentals	EN ISO 13849-1, EN 60204-1, EN 50178, EN 61800-3, IEC 61508 Part 1-7, EN 62061, IEC 61800-5-2
Object to be examined	SM100, type E94AYAB of the Servo Drives 9400 series
Test result	The module meets the requirements according to ISO 13849-1, category 4/PL e and of SIL 3 according to IEC 61508.
Special conditions	The safety instructions in the corresponding user documentation must be observed.
Place of issue	Cologne
Issue date	01.10.2007

1.3 Acceptance

1.3.1 Description

The machine manufacturer must check and prove the operability of the safety functions used.

Inspector

The machine manufacturer must authorise a person with expertise and knowledge of the safety functions to carry out the test.

Protocol

The test result of every safety function must be documented and signed.



Note!

If parameters of the safety function are changed, the test must be repeated and recorded in the test report.

Scope

A complete test comprises the following:

- ▶ Documentation of the plant including the safety functions.
 - Plant description and overview map
 - Description of the safety devices
 - Safety functions used
- ▶ Functional test of the safety functions used
- ▶ Preparing the test report
 - Documenting the functional test
 - Controlling the parameters
 - Signing
- ▶ Preparing the appendix with test records
 - Protocols from the plant
 - External recording

1.3.2 Periodic inspections

The correct sequence of the safety-oriented functions must be checked in periodic inspections. The risk analysis or applicable regulations determine the time distances between the tests. The inspection interval should not exceed one year.



© 06/2010

Lenze Automation GmbH
Hans-Lenze-Str. 1
D-31855 Aerzen
Germany



+49 (0)51 54 / 82-0



+49 (0)51 54 / 82 - 28 00



Lenze@Lenze.de



www.Lenze.com

Service

Lenze Service GmbH
Breslauer Straße 3
D-32699 Extertal
Germany



00 80 00 / 24 4 68 77 (24 h helpline)



+49 (0)51 54 / 82-11 12



Service@Lenze.de



EDS94AYAB ■ 13261738 ■ EN ■ 2.1 ■ TD00

10 9 8 7 6 5 4 3 2 1